

Prodigy DCC District Booster

(Item # 0001521)

1. Insulated rail joiners are needed at both ends of every "District."

2. Hook up your MRC DCC System, [Prodigy Advance, Advance Squared, Express, Express Squared, Wireless or Elite], as shown in the diagram, using the cables supplied with the booster. On Prodigy Advance and Advance Squared or Elite insert the cable into the "Factory Use Only" port, if using the Express, Express Squared or Wireless System; insert the cable into the "Booster Bus" port.

3. The 0001521 Booster "power in" terminals, from the included power supply are polarity sensitive; make sure the wires from the power supply are inserted correctly into the green plug that plugs into the Booster itself. The Booster is marked "DC Power (-) (+)". The red wire goes to plus (+), the black wire goes to minus (-). The two terminals on the green plug that line up with the "Track" output go to your district or to the layout itself.

Note*- if you are using your Booster to power the layout alone, [no districts], then just hook the "track" wires from your Booster to the layout. Do not use the "Main Track" output wires from your DCC System to the layout.

4. Power up your DCC System and the Booster. Polarity between the rails of each district must be checked with a voltmeter to ensure proper polarity between each district. Using your voltmeter set to the **A.C. scale**, check for polarity across the same rail across the insulated gap. If your meter shows A.C. voltage in the range of your DCC System track output, [normally approx. 14- 16 V.A.C.], it means you have different polarities across the rails, and this will result in a short circuit when the train crosses the gap. Change the two wires going to the district at either the track end, or at the green plug on the Booster itself. If your meter shows no voltage to little voltage, [some sensitive meters may show a small amount of voltage], the polarity across the rails are correct.

Caution: Power your DCC System and the Booster only with their included power supplies. Substituting other brands of power supplies may result in unbalanced track voltages and cause short circuits between districts on your layout.

Other makes of DCC Systems: This 8-amp Booster can be used with other makes of DCC Systems by modifying the supplied 8 conductor cable at one end, at the RJ45 plug

1. DCC System ground to pin # 1 or # 8 of the RJ45 plug (optional)
2. DCC System +5V to pin # 2 or # 7 of the RJ45 plug (optional)
3. Wire track "A" to pin # 3 or # 6 of the RJ45 plug (must be connected)
4. Wire track "B" to pin # 4 or # 5 of the RJ45 plug (must be connected)

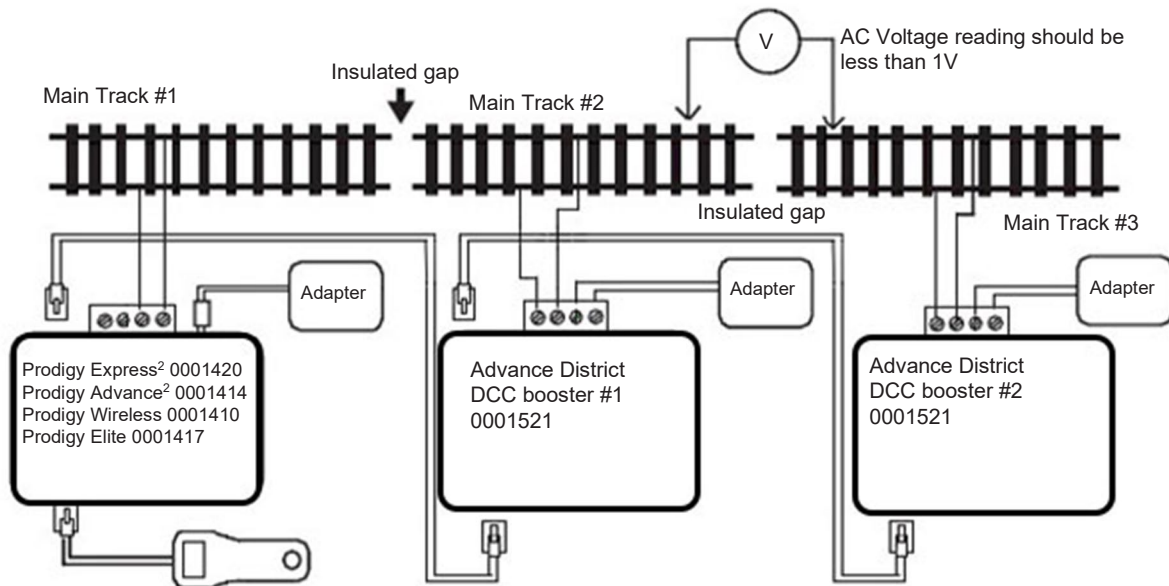

RETURN PROCEDURE

This Prodigy DCC District Booster carries a 6-month limited warranty against factory defects. This warranty does not include abuse, misuse, neglect, improper installation, or any modifications made to this device. The warranty does not include return shipping for customers outside of the continental United States (including Hawaii, Alaska, Canada, and Mexico). Customers outside of the continental United States must contact us for return shipping rates. If it should become necessary to return the Power Booster for warranty repair/replacement, be sure to contact MRC technical support beforehand to ensure you receive the correct fees for service. This also gives us the opportunity to troubleshoot issues which may be solved with technical phone support. In order to receive warranty service, we require a copy of the original sales receipt to validate the warranty period. Include a note briefly describing the issues along with your name, address, phone number, and email address.

Any questions regarding Warranty Policy can be directed to our Customer Service Department by calling 732-225-6360 between the hours of 8:00am and 5:00pm EST, or by emailing: mrcreport@modelrectifier.com

Send the Product to:

Model Rectifier Corporation
Attn: Parts & Service
360 Main Street, Suite 2.
Matawan, New Jersey 07747