

PROGRAMMING

This decoder supports all programming methods including: register, paged CV, direct CV, and programming on the main (ops mode programming).

CV	Register	Description	Range	Default
CV1	R1	Short address	1-127	3
CV2	R2	Start voltage	0-32	0
CV3	R3	Acceleration	0-32	0
CV4	R4	Deceleration	0-32	0
CV5	---	Top voltage	0-32	32
---	R6	Page number	---	---
CV29	R5	Basic configuration	---	2
CV7	R7	Manufacturer version number	---	32
CV8	R8	Manufacturer ID	---	143
CV17	---	Long address upper byte	192-231	192
CV18	---	Long address lower byte	0-255	3
CV19	---	Advanced consist address	0-127	0
CV21	--	When CV21=0, all accessory functions will follow its own address. When CV21=1, all functions will follow the consist address	---	0
CV49	---	Sound on/off (1=on)	0-1	1
CV51	---	Horn volume	0-3	3
CV53	---	Bell volume	0-3	3
CV54	---	Bell ring rate	0-50	3
CV55	---	Diesel rumble volume	0-3	3
CV56	---	Brake squeal volume	0-3	3
CV57	---	Dynamic brake volume	0-3	3
CV58	---	Air release volume	0-3	3
CV59	---	Air pump volume	0-3	3
CV60	---	Safety pop valve volume	0-3	3
CV61	---	Engine cooling fan volume	0-3	3
CV62	---	Coupling volume	0-3	3
CV63	---	Random noise volume	0-3	3
CV64	---	Rail wheel clack	0-3	3
CV105	---	User identification number	0-255	0
CV106	---	User identification number	0-255	0
CV112	---	Light effects	see chart	0
CV113	---	Ditch light rate	0--20	3
CV114	---	Light brightness (green, brown)	0-12	3
CV115	---	Auto brake squeal enable/disable	0-1	1(enable)
CV116	---	Coupling sound type	0-2, 2=off	1
CV117	---	Lights enable/disable	0-1	1(enable)
CV119	---	Coupling fire volume	0-3	3
CV120	---	Brake release volume	0-3	3
CV121	---	random noise enable	0-1	1(enable)
CV122	---	Diesel sound type (0=off, 1=rpm & notch synchro to speed, 2=linear rpm synchro to speed, 3=notch up/down (F8=notch down, F9=notch up))	0-3	1
CV124	---	Speed curve select (0=linear, 1=slow increase at slow speed, 2=fast increase at slow speed)	0-2	0
CV125	---	Factory default setting: Programming to 1 will restore all CV's to default setting	---	0

NOTE: Due to limitations in older DCC systems, some of the sound functions or light effects functions may not be accessible. ALSO, you might be limited to factory default CV values.

LIGHT EFFECT PROGRAMMING CHART FOR CV#112

Your MRC Synchronized Diesel Sound Decoder is equipped with normal directional lighting, plus MRC light effects. (see connect lights diagram) you can choose from ditch lights, mars light or strobe light. Your diesel loco can also have "Rule 17" directional headlights, through simple programming, without any complicated wiring.

Light Effect	Head Light	Head Light	Acc1 light	Acc2 light	CV value
CV#112	Normal on/off	Normal on/off	Ditch light	Ditch light	0
CV#112	Normal on/off	Normal on/off	Mars light	Single strobe light	1
CV#112	Normal on/off	Normal on/off	Mars light	Double strobe light	2
CV#112	Rule 17	Rule 17	Ditch light	Ditch light	16
CV#112	Rule 17	Rule 17	Mars light	Single strobe light	17
CV#112	Rule 17	Rule 17	Mars light	Double strobe light	18

UPGRADE

This decoder can be upgraded to MRC top line decoder performance that has 8 different bell sounds and 15 different horns. If you wish to upgrade your decoder please send in the decoder with \$24.00 check.

TROUBLE SHOOTING

The MRC 0001634 HO diesel sound decoder should perform well with all DCC systems. See your DCC system manual to learn how to program and operate the decoder. For more information about register/CVs and their functions, please refer to the NMRA DCC Standard & Recommended Practices, RP-9.2.2 this is available directly from the NMRA or their website at www.nmra.org.

Due to the nature of all sound decoders, the CV read back is not 100% correct. So this feature is not supported in the decoder. This is not a defect of the decoder or your DCC system.

Whenever the decoder doesn't work please use program track to re-program the loco address or program CV# 125 with value 1 to restore the decoder to factory setting. This should bring the decoder to life.

FCC COMPLIANCE

This device complies with the part 15 of FCC rule. Operation is subject to the following two conditions. (1) This device may not cause harmful interference, and (2) This device must accept any interference received, including interference that cause undesired operation.

RETURN PROCEDURE

If it should become necessary to return your decoder, unplug the decoder and return the decoder only. Please include a letter (printed clearly) with your name, address, a daytime telephone number, and a detailed description of the problem you are experiencing. Please also include a \$15.00 check for shipping and handling. **Be certain to return only the decoder.**

Send the decoder to:

Model Rectifier Corporation
Attn: Parts & Service
80 Newfield Avenue
Edison, NJ 08837-3817 U.S.A

© 2005 MODEL RECTIFIER CORPORATION
80 NEWFIELD AVENUE
EDISON, NJ 08837-3817

Printed in USA



HO Gauge EMD Modern Large Snap-in Diesel Sound Decoder with 17 Accessory Sound Functions

Item #0001634

Thank you for purchasing our highly advanced DCC locomotive sound decoder. Combined with any DCC System, our new decoder with authentic diesel sound truly will make your model railroad come to life.

- Replaces most locomotive circuit boards
- Synchronized diesel prime mover with randomly associated locomotive sounds
- 17 accessory functions allowing more sound control than ever
- Programmable individual sound volumes
- 1.5 amp capacity
- Programmable for either 2-digit (1-127) or 4-digit (1-9999) addresses
- Programmable start voltage
- Programmable acceleration rate
- Programmable deceleration rate
- Programmable top voltage
- Programmable 14, 28, 128 speed steps
- Selectable factory default speed curve
- Directional lighting (FO) at 0.2 amp rate
- Programmable "Rule 17" directional lighting
- Programmable for either ditch lights, mars light, or strobe light
- Supports advanced consist (CV19)
- Supports programming on the main (OPS mode)
- Compatible with NMRA DCC standards
- Complies with Part 15 of FCC
- 28mm speaker included
- Dimensions: 75.0mm x 17.5mm x 7.5mm

INSTALLATION

It is quite a challenge to install a decoder into a loco. You should have some basic electrical knowledge and soldering skills. If you do not have the above requirements, please ask the dealer for help in installation.

Figure 1 shows the electrical circuit of most standard locos. The terminals of the motor and light(s) are directly connected to the wheel pickup. Each type of loco has its own method of electrical pickup and distribution. The connection between the wheels, motor and light(s) could be wires, clips, the body or chassis, PC board or any other type of conductor. First, figure out your loco's electrical wiring and how to disconnect (isolate) the motor and light(s).

Figure 1. Connection of standard locomotive. *Note: The 'X' marks indicate where to disconnect (isolate).*

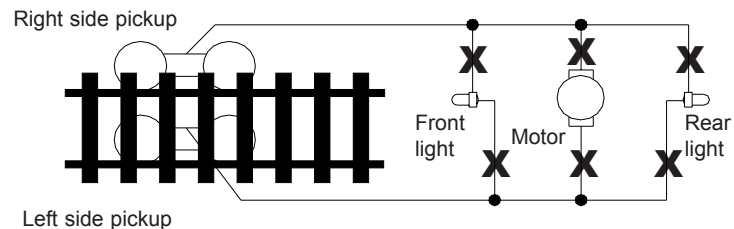

The decoder will be inserted between the wheel pickup and the motor.

Figure 2 shows how to connect 12V bulb, 1.5V bulb and LED lights.

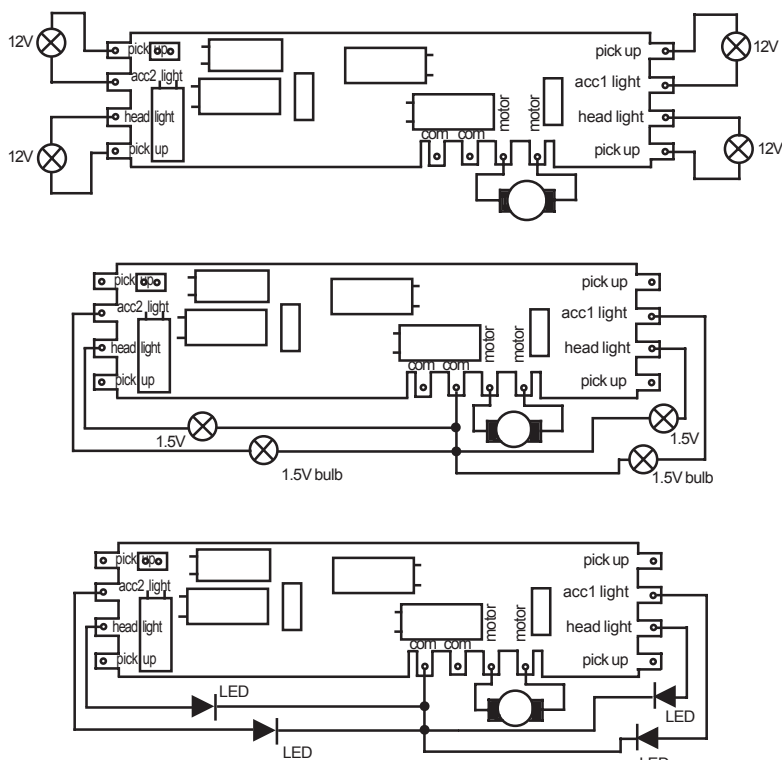

Each manufacturer and loco may have different ways of decoder installation. There is no standard rule for installing decoders. It is always better to consult the loco manufacturer on how to install a decoder in that particular loco.

LIGHT EFFECTS CONNECTION

If your loco has ditch lights, mars light or strobe light, you can connect these lights to the ACC1 and ACC2 extra tabs. Then program CV #112 for the desired light effect. CV #114 controls the output voltage (brightness) of the light effects.

The decoder allows you to use 1.5V/12V light bulb or LED Fig2 show how to connect your light.

SPEAKER SELECTION

The decoders come with a 28mm 8 ohm speaker. For narrow bodied locos, A 20mm round speaker or A 16x35mm rectangular speaker can also be purchased from MRC. However, reducing speaker size will affect the overall sound quality. Use hot glue or double-sided sticky tape to affix the speaker inside the loco shell. If the baffle is too tall, you may remove excess for desired height. Note: Completely removing the baffle will result in poor sound quality.

MAKING A TEST TRACK

Before you begin decoder installation, we strongly recommend building a test track with a 27 ohm resistor to limit current. Only test your installed decoder on the test track. The test track may prevent damage from an incorrectly installed decoder.

Note: The program track is NOT a test track. The program track does not use a current limiting resistor. So it can't protect an incorrectly installed decoder.

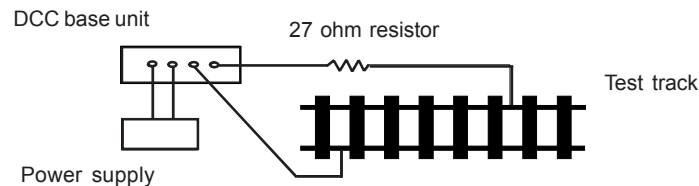

Figure 3. Diagram of test track

TESTING

All MRC decoders have been factory programmed with address #3, 28/128 speed steps and maximum top voltage. **Never run the installed decoder on your layout without first successfully running on test track.** Otherwise, you may damage the decoder if it is not wired correctly or if you have not properly isolated the motor and lights.

To test, place the loco on the test track. Select the "Run" mode of your DCC system and select or acquire address #3. Move up the throttle and the loco should move forward. Push the light button [F0] and the front headlight should come on. Change the direction of the loco and the loco should change direction and the rear headlight (if equipped) should come on. The loco cannot reach full speed, due to the resistor. If all above occurs, you passed the test. Congratulations!

Do not run the loco for an extended period of time on the test track or the resistor will overheat.

If your installed decoder does not pass the test, find the problem, correct it and test it again.

OPERATION

This decoder has engine start up and shut down sound. You must press any function key to start up the engine before operating the loco. The start up sound will enable only if you shut down the engine before turn off the power. To shut down the engine you must bring the loco to idle and then press F8 3 times.

This decoder can also be used in an Electric Type Traction Loco such as Trolley or GG-1 by turning off diesel sounds. To turn off the diesel prime mover sounds, program CV #122 with value 0.

There are many more program features available with this decoder. Please refer to the CV Chart to explore other features of the decoder.

DIESEL SOUNDS CHART

Function	Idle/Moving
Double click F0	Turns on/off accessory lighting
F1	Bell on/off
F2	Horn
F3	Air release while moving or prime mover rev up to high idle
F4	Coupling/air hose firing
F5	Brake release (idle) / brake squeal (moving)
F6	Dynamic brake on/off
F7	Air hose firing/uncoupling lever
F8	notch down n (when CV122=3)/associated loco sound
F9	notch up (when CV122=3)/associated loco sound
F10	Rail wheel clack (only moving)
F11	Traction air compressor
F12	Sound on/off
F13*	short air release
F14*	Associated loco sound
F15*	Air pump
F16*	Associated loco sound
F17*	flange noise

* Note: Only MRC Prodigy advance DCC has F13-F19 accessory functions
CV49 control sound on/off. Program CV49=0 turn off sound. Program CV49=1 turn on sound.

Note: Bell, Dynamic Brake and Rail Wheel Clack cannot play at the same time. If you active the Bell sound [F1], while either the Dynamic Brake or Rail Wheel Clack sounds are activated, the Bell sound will override the other 2 sounds. Rail Wheel Clack cannot play while the loco is in idle. When you turn off DynBrake and Rail Wheel Clack sound there will be one second delay.